

MR-BusIO-DCIN™ BusIO DC INPUT BOARD
User Manual

GRAVITECH.US



uResearch

GRAVITECH GROUP

Copyright © 2007 MicroResearch
GRAVITECH GROUP WWW.GRAVITECH.US

MR-BusIO-DCIN™ BusIO DC INPUT BOARD User Manual

Description

The MR-BusIO-DCIN is an experiment board for receiving 5V, 12V or 24VDC input and translates into TTL 5VDC level. It is using PC817 Photo-coupler IC to isolate high current and low current. It is best for monitoring the present of DC voltage.

The board can be use with MR-BusIO-MAIN board or stand-alone. PCB size is 0.63" x 2.80"

Operation:

The PC817 require at least 5mA to drive input photo-coupler LED. It can take up to 6V in reverse bias. For an output (between collector and emitter), it can drive up to 35V with 50mA continuous current.

The operation of this board starts when it's receiving input DC voltage from 2-PIN terminal block. The current will be limited around 9-10mA (enough to turn on PC817). The output of photo-coupler then pulls the I/O pin LOW then an indicator LED is illuminated. In case of user need to apply input voltage beyond 5V, 12V or 24V, the new current limited resistor can be calculate by $I=V/R$ when $I=9mA$.

User must set the jumper to appropriate input voltage. This board can be use to detect DC voltage.



MR-BusIO-MAIN

The MR-BusIO-MAIN is available for purchase via our website. If you don't see the item you need, please contract our sales department at sales@gravitech.us

- **MR-BusIO-MAIN**

Experiment board which receives output signals from any microcontrollers. The signals then distribute to daughter boards for each experiment. It designed to connect directly with 10PIN MRconnect®. It is a quick and easy way to control up to 8 daughter boards.



MR-BusIO-DCIN™ BusIO DC INPUT BOARD User Manual

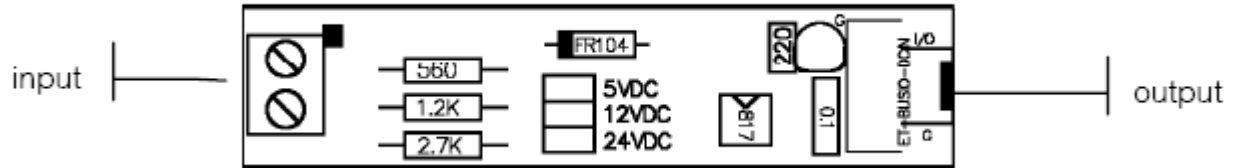

FIG 1: MR-BusIO-DCIN Board Layout

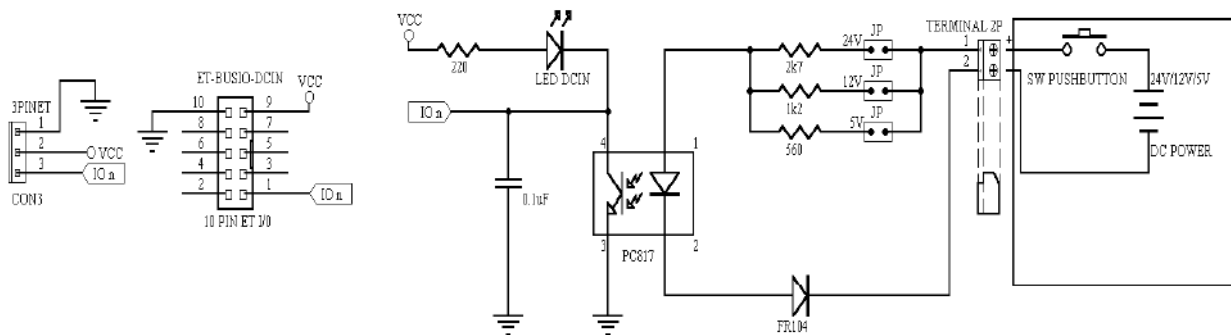

FIG 2: MR-BusIO-DCIN Schematic

MR-BusIO-DCIN™ BusIO DC INPUT BOARD User Manual

Notes

Contact Us

We maintain a website where you can get information on our products, obtain literature and download support files. Visit us online at:

WWW.GRAVITECH.US

Use our online Forum or e-mail your technical support questions to support@gravitech.us. We try to respond to your questions the same day.

For sales questions or to place and order, direct your e-mails to sales@gravitech.us. Refer to our website for product pricing, shipping rates, payment instructions, and for other info we need to complete your order.

Disclaimer: MicroResearch reserves the right to modify its products or literature, or to discontinue any product at any time without prior notice. The customer is responsible for determining the suitability of any device for any application developed using MicroResearch components.

Copyright © 2007 MicroResearch
GRAVITECH GROUP WWW.GRAVITECH.US